



EPL185

ELECTRIC PALLET TRUCK 1.8T

1800 kg 115 mm 48 V Li-Ion



Ideal for warehouses, retail, and logistics environments, the EPL185 is designed for operations requiring both high load capacity and maneuverability. Its compact chassis (400 mm fork face length) makes it suitable for confined spaces, while the stabilizing wheels ensure balance even on uneven surfaces. Thanks to optional fork dimensions, larger battery capacities, and additional attachments, it adapts to diverse customer requirements.

SPECIFICATION	REF	UNIT	VALUE
Battery type			Li-Ion
Battery nominal capacity K5		Ah	20
Battery voltage		V	48
Rated capacity	Q	kg	1800
Load centre distance	c	mm	600
Service weight		kg	170
Lift	h_3	mm	115
Overall length	l_1	mm	1550
Overall width	b_1/b_2	mm	610 (695)
Length to face of forks	l_2	mm	400
Fork dimensions	s/e/l	mm	50x150x1150
Turning radius	Wa	mm	1330
Manufacturer			EP
Model designation			EPL185
Drive			Electric
Operator type			Pedestrian

Features

Stable and safe handling

Industrial floating stabilizing wheels come as standard, providing excellent stability and smooth load transport, even on slightly uneven floors.



Advanced battery system

Equipped with a 48V/20Ah removable Li-ion battery with BMS and CAN technology, the EPL185 offers safety, reliability, and the flexibility of optional 30Ah capacity.

Brushless drive technology

The brushless DC motor eliminates the need for carbon brush replacement, improving efficiency and reducing maintenance while ensuring stronger driving power.



Compact & maneuverable

With only 400 mm fork face length and 170 kg service weight, the EPL185 is compact enough for tight aisles but strong enough to handle loads up to 1.8 tons.

VDI Chart

	SPECIFICATION	REF	UNIT	VALUE
1.1	Manufacturer			EP
1.2	Model designation			EPL185
1.3	Drive			Electric
1.4	Operator type			Pedestrian
1.5	Rated capacity	Q	kg	1800
1.6	Load centre distance	c	mm	600
1.8	Load distance, centre of drive axle to fork	x	mm	940
1.9	Wheelbase	y	mm	1200
2.1	Service weight		kg	170
2.2	Axle loading, laden front/rear		kg	640/1330
2.3	Axle loading, unladen front/rear		kg	130/40
3.1	Tyres			Polyurethane
3.2	Tyre size, front		mm	210x70
3.3	Tyre size, rear		mm	80x61/88x78
3.5	Wheels, number front/rear (x=drive wheels)			1x 2/4(1x 2/2)
3.6	Tread width, front	b ₁₀	mm	450
3.7	Tread width, rear	b ₁₁	mm	390/(535)
4.4	Lift	h ₃	mm	115
4.19	Overall length	l ₁	mm	1550
4.20	Length to face of forks	l ₂	mm	400
4.21	Overall width	b ₁ /b ₂	mm	610 (695)
4.22	Fork dimensions	s/e/l	mm	50x150x1150
4.34.1	Aisle width for pallets 1000x1200 crossways	Ast	mm	2094
4.34.2	Aisle width for pallets 800 x 1200 lengthways	Ast	mm	2146
4.35	Turning radius	Wa	mm	1330
5.1	Travel speed, laden/unladen		km/h	5/5.5
5.2	Lift speed, laden/unladen		m/s	0.020/0.025
5.3	Lowering speed, laden/unladen		m/s	0.065/0.030
5.8	Max. gradeability, laden/unladen		%	6/16
5.10	Service brake			Electromagnetic
6.1	Drive motor rating S2 60 min		kW	0.9
6.2	Lift motor rating at S3 15%		kW	0.8

	SPECIFICATION	REF	UNIT	VALUE
6.4	Battery nominal capacity K5		Ah	20
6.4	Battery voltage		V	48
6.4.1	Battery type			Li-Ion
6.5	Battery weight		kg	14
8.1	Type of drive unit			DC
10.5	Steering design			Mechanical
10.7	Sound pressure level at the driver's seat		dB(A)	74

VDI Drawing

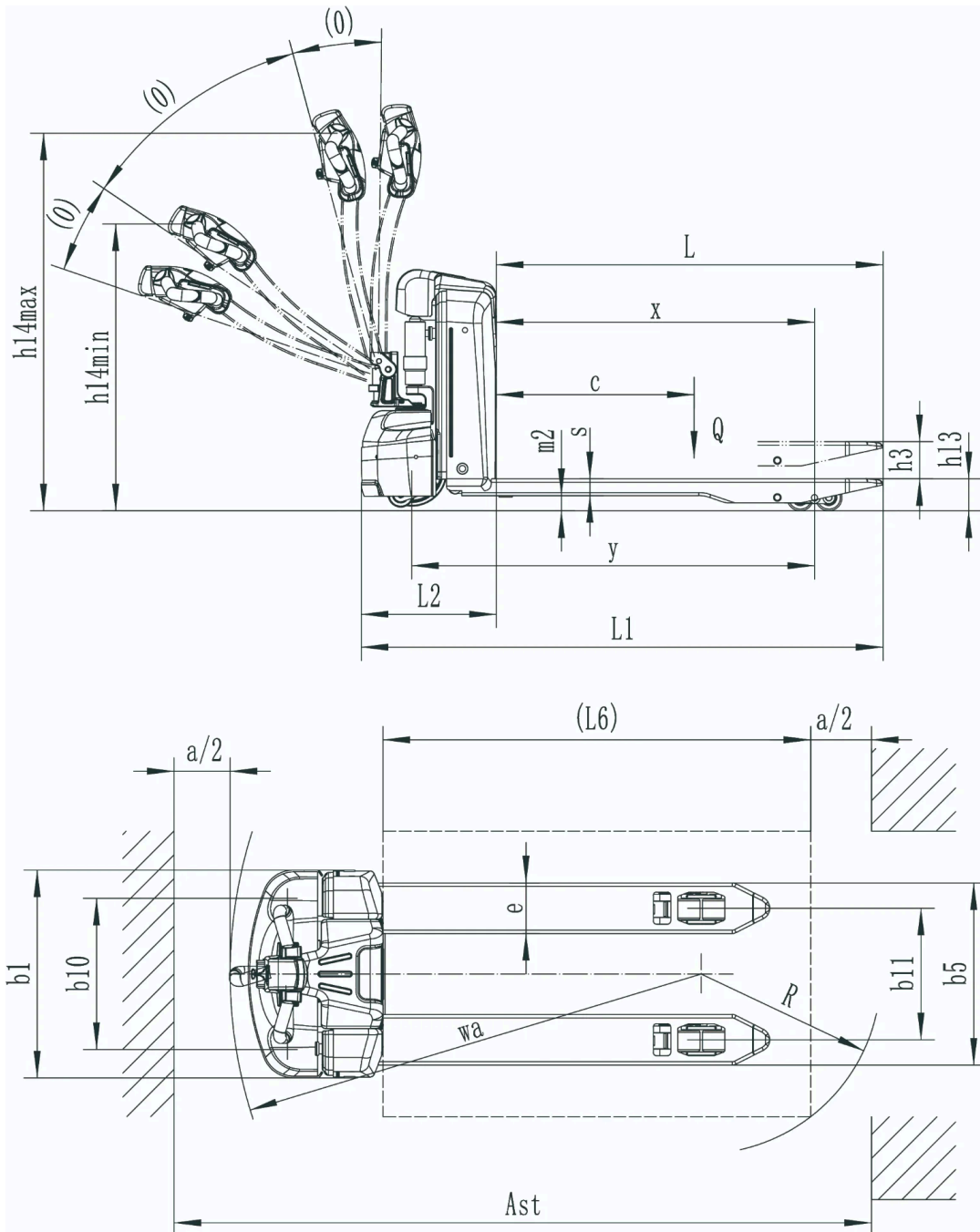

Options

ITEM	OPTIONS (optional items marked in yellow)
Fork dimension	540*1150 540*900 540*1000 540*1220 540*1300 540*1400 540*1500 685*900 685*1000 685*1150 685*1220 685*1300 685*1400 685*1500
Fork lowered height	80
Fork carriage height option	Optional : 1220mm (48in) Optional : 1520mm (60in)
Load wheel type	Double Single
Load wheel material	PU
Drive wheel material	PU
Battery capacity	20Ah 30Ah
Charger	48V-10A integrated 48V-10A external
Battery display indicator (BDI)	without hourmeter
Castor wheels	No Yes and not customized
Buzzer	Yes and not customized