



CQD 14/16 ^{PRO}

80V LI-ION REACH TRUCK 1400/1600KG



EP EQUIPMENT ^{PRO}



Compact Design for Tight Spaces

The CQD 14/16 PRO is engineered for optimal space efficiency. With a working aisle width of 2701mm, it offers the agility in narrow aisles and in high-density racking. Its compact dimensions and tight turning radius make it highly competitive among peers.



working aisle width

2701mm

PRECISE
GENTLE

Proportional Lifting for Precision

The CQD 14/16 PRO is equipped with a proportional lifting system that ensures precise and gentle lifting and lowering. It provides a cushioning effect to minimize vibrations when handling fragile or heavy loads.



Unmatched Stability with the Enhanced Mast

The new mast demonstrates overall improvements. It reaches up to 8m for the CQD 14 PRO and 9.65m for the CQD 16 PRO, while maintaining full residual capacity up to 7.5m for the CQD 14 PRO and 7m for the CQD 16 PRO. Even at full height, the mast remains highly stable when driving the truck. The exceptional stability makes the CQD 14/16 PRO a workhorse in demanding conditions.

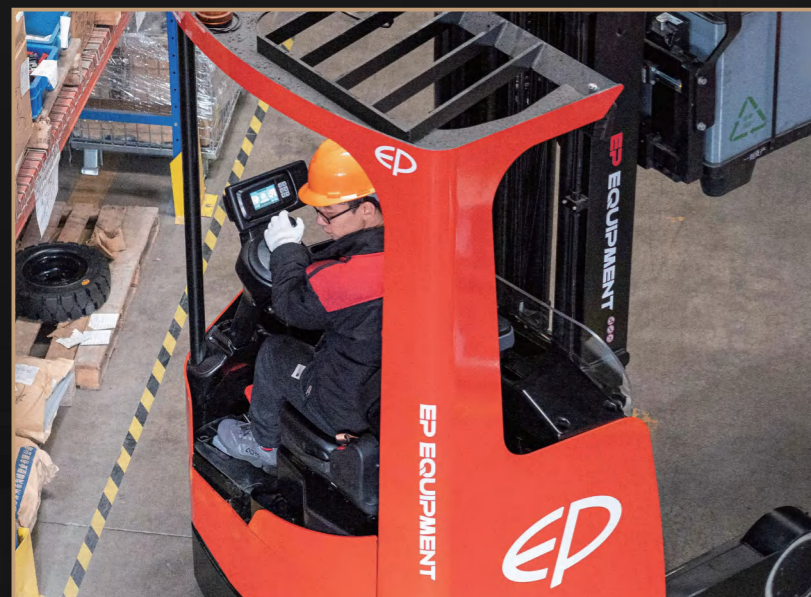

All-round Visibility for Added Safety

With the spacious cab and optimized design, the CQD 14/16 PRO provides operators with clear and unobstructed visibility of goods and surroundings. It allows operators to work confidently in crowded environments.

Electric Steering with Damping

The CQD 14/16 PRO features electric steering with damping which enhances the stability and control. This is significant for high performance, especially at tight turns or when handling heavy loads. It ensures a smoother and more comfortable driving experience.



CQD 14/16 PRO

80V LI-ION REACH TRUCK 1400/1600KG



Max. Lifting speed 0.6m/s
Max. Lowering speed 0.55m/s



Max. reach distance = 600mm

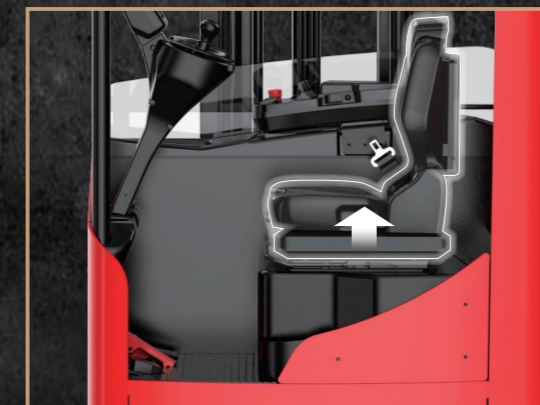

Spacious legroom



Turnable seat for easy maintenance



PRO

a turning radius of 1680mm

CQD 14/16 PRO

Li-ion Reach Truck 1400/1600kg



Fingertip or joystick hydraulic controls



External charging port with a protective cover



Full-color display



CQD 14/16 PRO

Li-ion Reach Truck 1400/1600kg

Distinguishing mark	1.1	Manufacturer			EP	EP
	1.2	Model designation			CQD 14 PRO	CQD 16 PRO
	1.3	Drive unit			Electric	Electric
	1.4	Operator type			Seated	Seated
	1.5	rated capacity	Q	kg	1400	1600
	1.6	Load center distance	c	mm	600	600
	1.8	Load distance, centre of drive axle to fork	x	mm	340	390
	1.9	Wheelbase	y	mm	1365	1415
	Service weight	2.1	Service weight		kg	3880
2.3.1		Axle loading, unladen front/rear		kg	2495/1415	2580/1500
2.4.1		Axle loading, fork advanced, laden front/rear		kg	1085/4250	1045/4775
Tyres/chassis	2.5.1	Axle loading, fork retracted, laden front/rear		kg	2285/3045	2280/3495
	3.1	Tyre type		mm	Polyurethane	Polyurethane
	3.2.1	Tyre size, front		mm	Φ343×140	Φ343×140
	3.3.1	Tyre size, rear		mm	Φ285×100	Φ285×100
	3.5.1	Wheels, number front/rear (x=drive wheels)		mm	1x/2	1x/2
Dimensions	3.7	Tread, rear	b11	mm	1168	1168
	4.1	Tilt of mast/fork carriage forward/backward	α/β	°	2/4	2/4
	4.2	Height, mast lowered	h1	mm	3383	3930
	4.3	Free lift	h2	mm	2330	2877
	4.4	Lift height	h3	mm	8000	9655
	4.5	Height, mast extended	h4	mm	8730	10720
	4.7	Height of overhead/ guard cabin	h6	mm	2200	2200
	4.8	Seat height/standing height	h7	mm	1000	1000
	4.10	Height of wheel arms	h8	mm	308	308
	4.19	Overall length	l1	mm	2415	2465
	4.20	Length to face of forks	l2	mm	1265	1265
	4.21	Overall width	b1/b2	mm	1250/1270	1250/1270
	4.22	Fork dimensions	s/e/l	mm	40/100/1150	40/100/1150
	4.23	A,B Fork carriage class/type A, B			2A	2A
	4.24	Fork carriage width	b3	mm	990	990
	4.25	Distance between fork-arms	b5	mm	200/770	200/770
	4.26	Distance between wheel arms/loading surfaces	b4	mm	917	917
	4.28	Reach distance	l4	mm	550	600
	4.31	Ground clearance, laden, below mast	m1	mm	75	75
	4.32	Ground clearance, center of wheelbase	m2	mm	70	70
	4.34.1	Aisle width for pallets 1000×1200 crossways	Ast	mm	2701	2715
	4.34.2	Aisle width for pallets 800×1200 crossways	Ast	mm	2755	2760
	4.35	turning radius	Wa	mm	1629	1680
	4.37	Length across wheel arms	l7	mm	1770	1820
Performance data	5.1	Travel speed, laden/unladen		km/ h	11/11	11/11
	5.2	Lifting speed, laden/unladen		m/s	0.45/0.6	0.42/0.6
	5.3	Lowering speed, laden/unladen		m/s	0.54/0.50	0.55/0.50
	5.4	Reaching speed, laden /unladen		m/s	0.18	0.18
	5.8	Max. gradeability, laden/unladen		%	10/15	10/15
	5.10	Service brake			Electromagnetic	Electromagnetic
5.11	Parking brake			Electromagnetic	Electromagnetic	
Electric-engine	6.1	Drive motor rating S2 60 min		kW	8	8
	6.2	Lift motor rating at S3 15%		kW	22	22
	6.4	Battery voltage/nominal capacity		V/Ah	80/150/205/280	80/150/205/280
Addition data	6.5	Battery weight		kg	149/180/209	149/180/209
	8.1	Type of drive unit			AC	AC
	10.5	Steering design			Electronic	Electronic
	10.7	Sound pressure level at the driver's ear		dB(A)	70	70

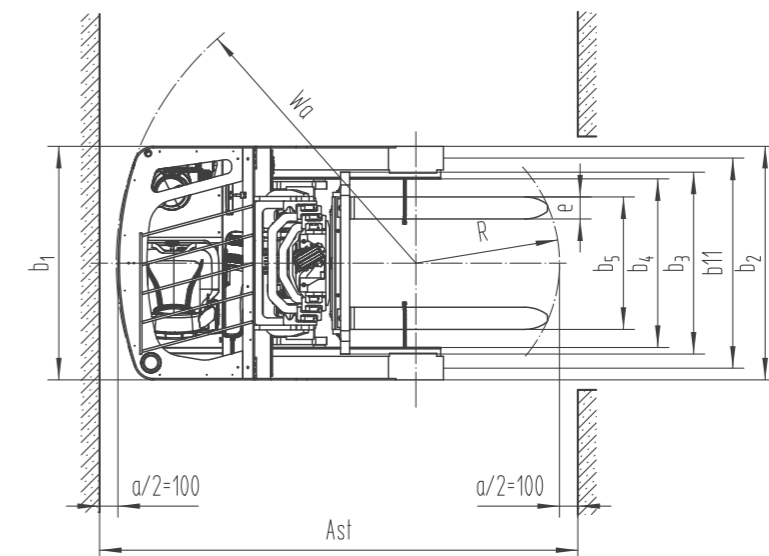
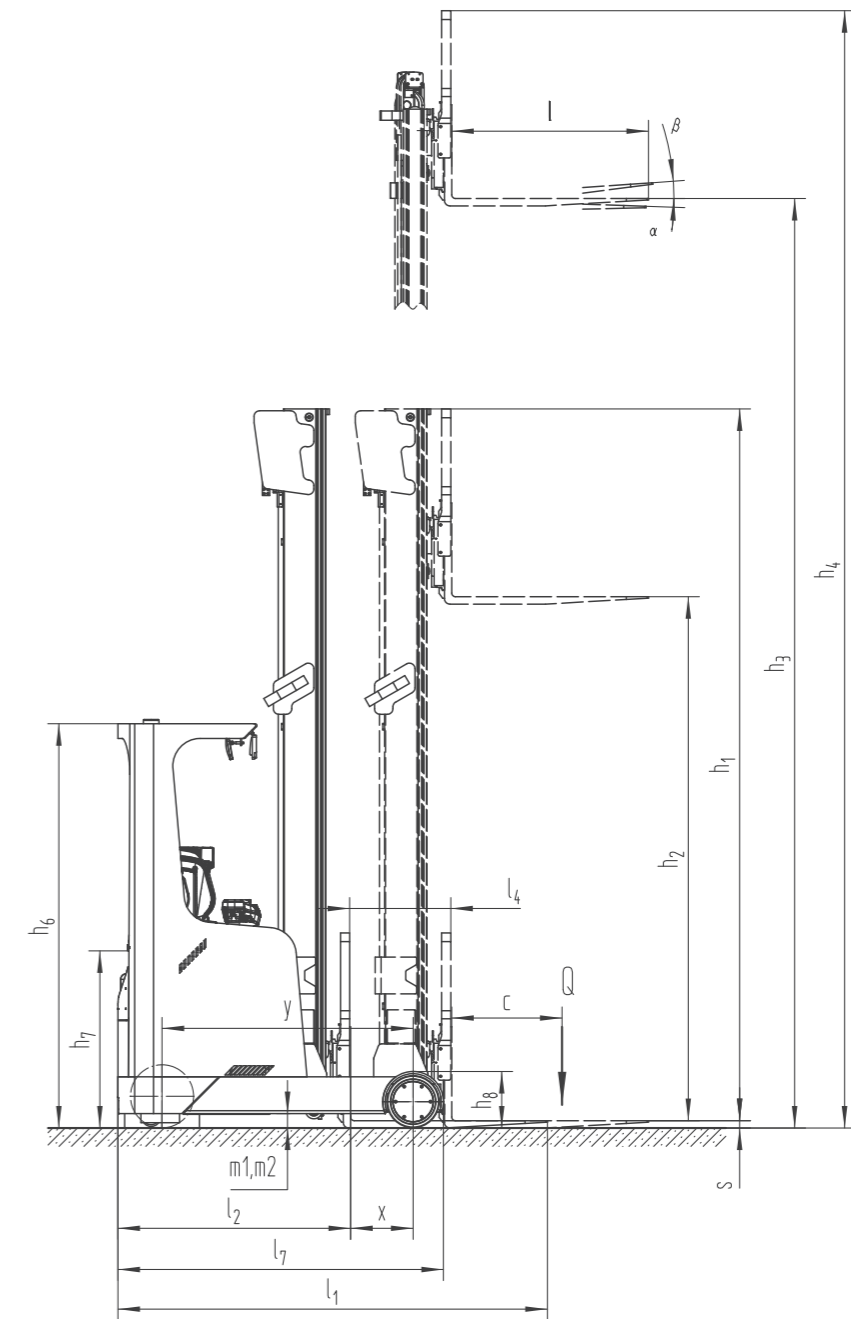

RATED CAPACITIES GRAPH

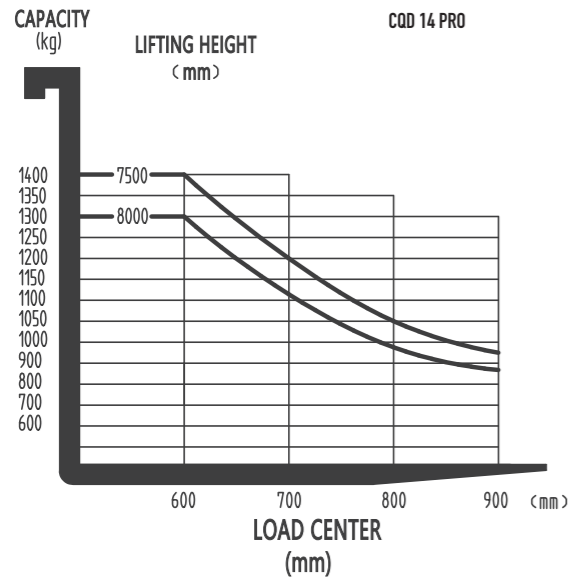

RATED CAPACITIES GRAPH

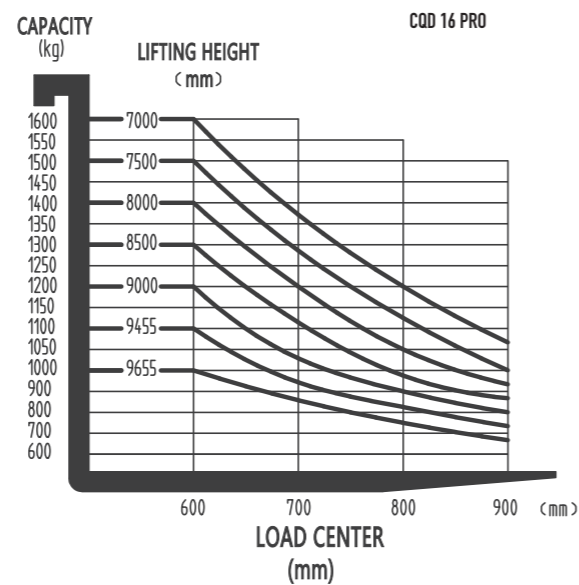

Mast Option:

CQD 14 PRO

Mast types	Lift height (h3) mm	Height, Mast		Height, Free lift(h2)		
		Height, mast lowered(h1) mm	Height, mast extended(h4) mm		No backrest mm	With backrest mm
			No backrest	With backrest		
3-Free Mast	4000	1968	4730	5065	1044	915
	4500	2138	5230	5565	1214	1085
	5000	2303	5730	6065	1380	1250
	5500	2468	6230	6565	1544	1415
	6000	2638	6730	7065	1714	1585
	6500	2810	7230	7565	1888	1757
	7000	3048	7730	8065	2124	1995
	7500	3218	8230	8565	2294	2165
	8000	3383	8730	9065	2460	2330

CQD 16 PRO

Mast types	Lift height (h3) mm	Height, Mast		Height, Free lift(h2)		
		Height, mast lowered(h1) mm	Height, mast extended(h4) mm		No backrest mm	With backrest mm
			No backrest	With backrest		
3-Free Mast	4000	1968	4730	5065	1044	915
	4500	2138	5230	5565	1214	1085
	5000	2303	5730	6065	1380	1250
	5500	2468	6230	6565	1544	1415
	6000	2638	6730	7065	1714	1585
	6500	2810	7230	7565	1888	1757
	7000	3048	7730	8065	2124	1995
	7500	3218	8230	8565	2294	2165
	8000	3383	8730	9065	2460	2330
	8500	3603	9230	9565	2680	2550
	9000	3768	9730	10065	2844	2715
	9655	3930	10385	10720	3008	2877

Option:

Option Items	CQD 14/16 PRO
Fork dimension	○No○100*40*920○100*40*1070●100*40*1150 ○100*40*1220○100*40*1370○100*40*1520
Reach lift truck Leg width	●917
Fork carriage width	●770mm
Load backrest height	●1020mm
Load wheel type	●Single
Load wheel material	●PU
Drive wheel material	●PU
Battery capacity	●205Ah-Li○280Ah-Li○150Ah-Li○No
Charger	●80V-100A-Li External○80V-150A-Li External○ No
Seat type	●Suspension○Suspension + safety belt logic switch
Attachments	●Built-in sidershifter
Guard board	●Yes
Front lamp	●LED
Rear lamp	●No○LED
Warning lamp	●Yes and not customized
Blue lamp	●No○Yes and not customized
Rearview mirror	●Yes
Buzzer	●No○Yes and not customized
Height display	●Yes and not customized
Camera	●No○Yes and not customized
Fire extinguisher holder	●No○Yes and not customized
OPS system	●Yes and not customized
Telematics	●Yes and not customized
Turn speed control	●Yes and not customized
Heating system during lithium battery charging	●No○Yes and not customized
Speed reduction with elevated mast	●Yes
Operator identification device	●No○Card reader○Fingerprint lock
Cold storage	●No○Yes and not customized
Drive assembly	●ZK25
Forks tilt forward and backward	●Yes and not customized
Overhead guard	●Yes○Drive-in
Hydraulic lever system	●Fingertips○Joysticks

Note: ●Standard ○ Optional - Inconformity: