



TVL151

3-WHEEL DUAL-DRIVE COUNTERBALANCE FORKLIFT 1500KG

1500 kg 5000 mm 80 V Li-Ion



Narrow Aisle: This counterbalance forklift can be used for a range of work applications including indoor warehousing and narrow aisle, with a turning radius starting from 1450mm for TVL151 to 1585mm for TVL201.

Loading/Unloading: It offers great performance in loading and unloading tasks at docks or side bay lorries, supported by its powerful 80V battery. Ideal for the rental business due to its opportunity charging capability.

SPECIFICATION	REF	UNIT	VALUE
Battery type			Li-Ion
Battery nominal capacity K5		Ah	150
Battery voltage		V	80
Rated capacity	Q	kg	1500
Load centre distance	c	mm	500
Service weight		kg	2950
Height, mast lowered	h_1	mm	2075
Lift	h_3	mm	3000
Height, mast extended	h_4	mm	4055
Overall length	l_1	mm	2733
Overall width	b_1/b_2	mm	1100
Length to face of forks	l_2	mm	1813
Fork dimensions	s/e/l	mm	100X40X920
Turning radius	Wa	mm	1450
Manufacturer			EP
Model designation			TVL151

Features

80 Volt System Offering Powerful Performance

The 80 voltage 2*5.0 kW dual drive motors offer higher power efficiency than regular 48 voltage, thus the TVL series has greatly enhanced its productivity of 6 working hours per charge.



Large Workspace

Due to the compact size of EP lithium battery and the ergonomic configuration of the control levers and the foot brake pedal, the small truck offers spacious legroom of 394mm and delivers the best in operation comfort.

Compact Truck Size

The TVL series features a small turning radius, 1450mm of TVL151, 1550mm of TVL181 and 1585mm of TVL201, which makes it a perfect workhorse for small warehouses with narrow aisles within 3.5 m.



Integrated Charger

The TVL series forklift comes with a EP Li-Ion battery and a 35A single phase integrated charger with 16 amp plug allowing the truck to be charged at any power outlets (except 10A and 13A civil plug in Switzerland and England).

Enhanced Mast with Optimal Visibility & Stability

The TVL series adopts the same high-strengthened mast of CPD20L2, offering the best all-around visibility and great stability with less wobbling even fully loaded.



VDI Chart

	SPECIFICATION	REF	UNIT	VALUE
1.1	Manufacturer			EP
1.2	Model designation			TVL151
1.3	Drive			Electric
1.4	Operator type			Seated
1.5	Rated capacity	Q	kg	1500
1.6	Load centre distance	c	mm	500
1.8	Load distance, centre of drive axle to fork	x	mm	420
1.9	Wheelbase	y	mm	1230
2.1	Service weight		kg	2950
2.2	Axle loading, laden front/rear		kg	3928/522
2.3	Axle loading, unladen front/rear		kg	1305/1645
3.1	Tyres			Solid
3.2	Tyre size, front		mm	18X7-8
3.3	Tyre size, rear		mm	15X4.5-8
3.5	Wheels, number front/rear (x=drive wheels)			2X/2
3.6	Tread width, front	b ₁₀	mm	943
3.7	Tread width, rear	b ₁₁	mm	175
4.1	Tilt of mast/fork carriage forward/backward		°	5/5
4.2	Height, mast lowered	h ₁	mm	2075
4.3	Free lift	h ₂	mm	100
4.4	Lift	h ₃	mm	3000
4.5	Height, mast extended	h ₄	mm	4055
4.7	Height of overhead guard (cabin)	h ₆	mm	2078
4.8	Seat height relating to SIP/stand height	h ₇	mm	1050
4.12	Coupling height	h ₁₀	mm	600
4.19	Overall length	l ₁	mm	2733
4.20	Length to face of forks	l ₂	mm	1813
4.21	Overall width	b ₁ /b ₂	mm	1100
4.22	Fork dimensions	s/e/l	mm	100X40X920
4.23	Fork carriage ISO 2328, class/type A, B			2A
4.24	Fork carriage width		mm	1040
4.31	Ground clearance, laden, below mast		mm	89

SPECIFICATION		REF	UNIT	VALUE
4.32	Ground clearance, centre of wheelbase	m ₂	mm	92
4.34.1	Aisle width for pallets 1000×1200 crossways	Ast	mm	3175
4.34.2	Aisle width for pallets 800 × 1200 lengthways	Ast	mm	3300
4.35	Turning radius	Wa	mm	1450
5.1	Travel speed, laden/unladen		km/h	13/14
5.2	Lift speed, laden/unladen		m/s	0.33/0.45
5.3	Lowering speed, laden/unladen		m/s	0.4/0.44
5.8	Max. gradeability, laden/unladen		%	10/15
5.10	Service brake			Hydraulic
5.11	Parking brake			Mechanical
6.1	Drive motor rating S2 60 min		kW	5.0X2
6.2	Lift motor rating at S3 15%		kW	11
6.4	Battery nominal capacity K5		Ah	150
6.4	Battery voltage		V	80
6.4.1	Battery type			Li-Ion
6.5	Battery weight		kg	165
6.6	Energy consumption according to DIN EN 16796		kWh/h	5.29
6.7	Turnover output according to VDI 2198			96
6.8	Turnover efficiency according to VDI 2198			19.22
8.1	Type of drive unit			AC
10.1	Operating pressure for attachments		bar	180
10.2	Oil volume for attachments		ℓ/min	25
10.5	Steering design			Hydraulic
10.7	Sound pressure level at the driver's seat		dB(A)	68

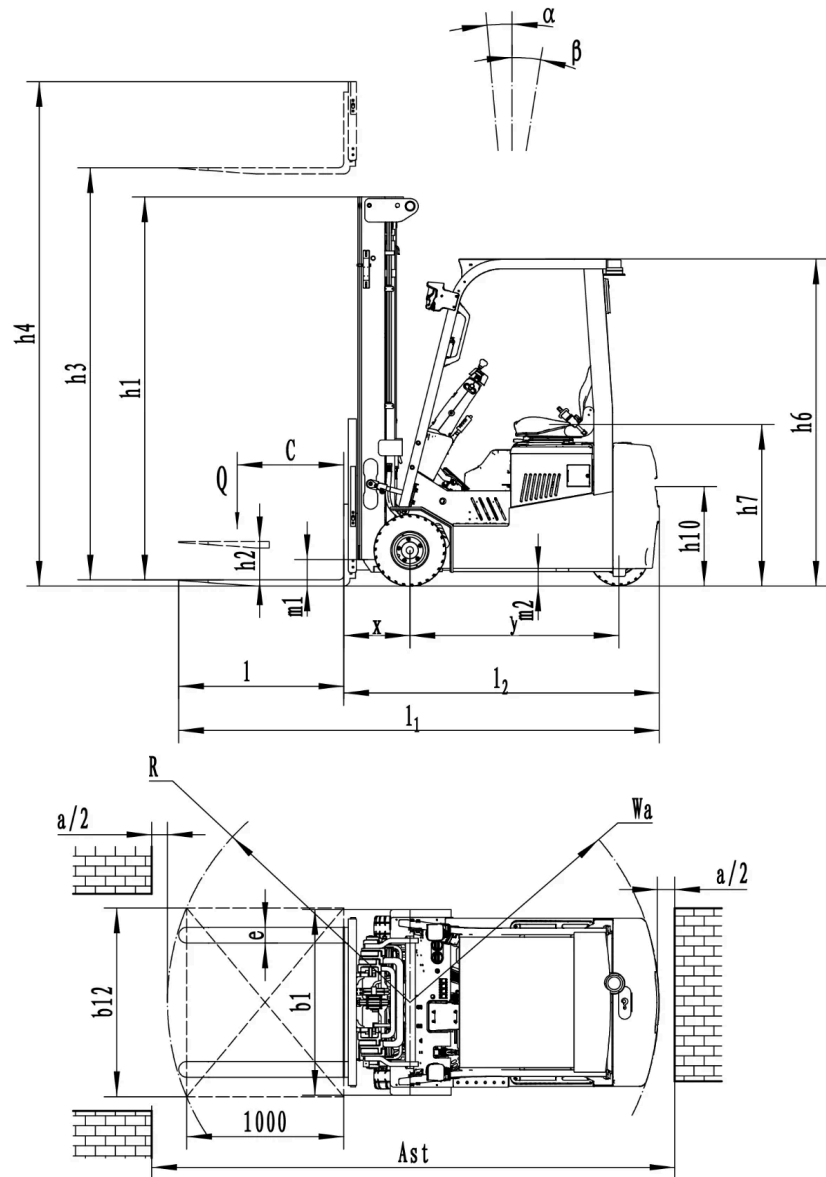

RATED CAPACITIES AND LOAD CENTERES GRAPH

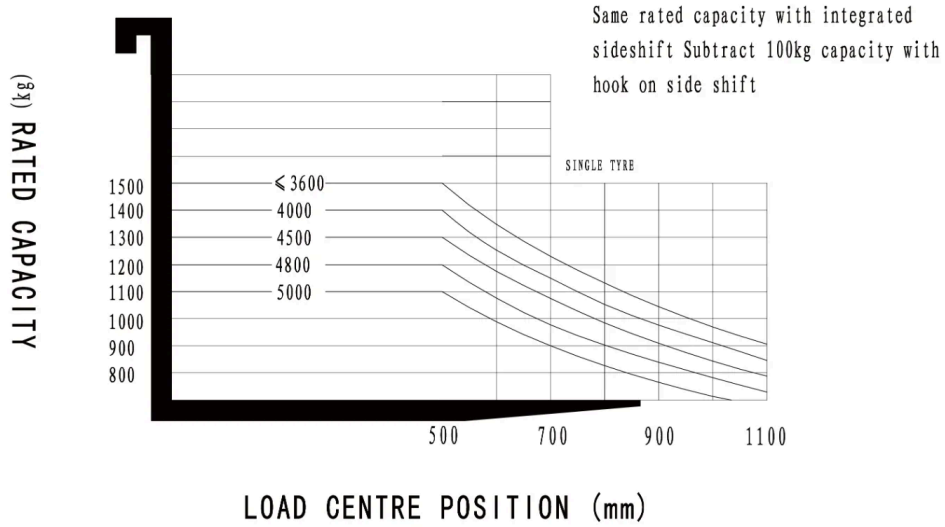

Mast Options

MAST TYPE	LIFT HEIGHT (H3, MM)	MAST LOWERED HEIGHT (H1, MM)	MAST EXTENDED HEIGHT, NO BACKREST (H4, MM)	MAST EXTENDED HEIGHT, WITH BACKREST (H4, MM)	FREE LIFT HEIGHT, NO BACKREST (H2, MM)	FREE LIFT HEIGHT, WITH BACKREST (H2, MM)
2-Standard Mast	3000	2075	3740	4055	100	100
2-Standard Mast	3600	2375	4340	4655	100	100
2-Standard Mast	4000	2455	4740	5055	100	100
3-Free Mast	4500	2140	5240	5555	1430	1115
3-Free Mast	4800	2240	5540	5855	1530	1215
3-Free Mast	5000	2305	5740	6055	1595	1280

Options

ITEM	OPTIONS (optional items marked in yellow)
Fork dimension	100*40*920 100*40*1070 100*40*1150 100*40*1200 100*40*1220 100*40*1370
Fork carriage width option	1040mm Yes and can be customized
Fork carriage height option	1067mm (42in) 1220mm (48in) 1520mm (60in) Yes and not customized
Front wheel material	Solid rubber Yes and not customized

ITEM	OPTIONS (optional items marked in yellow)
Rear wheel material	Solid rubber Yes and not customized
Battery capacity	150Ah 205Ah 280Ah
Charger	80V-35A single-phase integrated 80V-60A 3-phase integrated 80V-35A single-phase external 80V-65A 3-phase external
Battery display indicator (BDI)	With hourmeter
Seat type	Regular Premium Suspension Suspension+seatbelt logic switch
Attachments	No Built-in sidsifter External shifter Adjustable fork
Traction pin	Yes
Anti-static chain	Yes
Front lamp	LED
Rear lamp	No LED
Warning lamp	YES
Blue lamp	No 2 front 1 rear 2 front+ 1 rear
Area warning lamp	No 1 left + 1 right (Red)
Rearview mirror	1 in the middle Add 1 rearview mirror on both sides
Buzzer	YES
OPS system	YES
Telematics	No Yes and not customized
Cabin	No Basic half cabin Upgrade half cabin Full cabin
Wiper water unit	No Yes, only with cabin and not customized